

CUBA FRIA CFG-GI						COD. PIEZA: X										
COTAS SIN TOLERANCIA DIN 7168-f						Material:				SUSTITUYE A:						
ANGULAR	GRADO TOLERANCIA	FINO	MEDIO	GRUESO	Acabado:								SUSTITUIDO POR:			
	HASTA 10 mm	±1°		±1° 30'	COMUN A	MODELO	Ud.	MODELO	Ud.	MODELO	Ud.	MODELO	Ud.	MODELO	Ud.	
	MAS DE 10 A 50 mm	±30'		±50'		CFG-GI	1									
	MAS DE 50 A 120 mm	±20'		±25'												
	MAS DE 120 A 400 mm	±10'		±15'												
MAS DE 400 mm	±5'		±10'													
LINEAL	GRADO TOLERANCIA	FINO	MEDIO	GRUESO	A4		Nombre		Fecha							
	HASTA 3 mm	±0,05	±0,10	±0,15	Dibujado		JAPM		. 21-5-01							
	MAS DE 3 A 6 mm	±0,05	±0,10	±0,20	Comprobado											
	MAS DE 6 A 30 mm	±0,10	±0,20	±0,50	Escala											
	MAS DE 30 A 120 mm	±0,15	±0,30	±0,80	1:14		PLANO RECAMBIOS				Código máquina:					
	MAS DE 120 A 400 mm	±0,20	±0,50	±1,20							CODIGO					
	MAS DE 400 A 1000 mm	±0,30	±0,80	±2,00												
MAS DE 1000 A 2000 mm	±0,50	±1,20	±3,00													

Marca	Código	Denominación	CF3G-7-GI	CF4G-7-GI	CF5G-7-GI
1	6021350015	Termostato term. refriger. ID 961F	x	x	x
2	6021130001	Interruptor bipolar luminoso ambar	x	x	x
3	6021130003	Piloto ambar indicador función	x	x	x
4	6021390006	Manguera 3x1x2500 mm. Blanca clavija schuko	x	x	x
6	C377010002	Cuadro de Mandos CCGN, CH-4, CFG, CPH	x	x	x
8	6021010004	Compresor	x		
8	6021010007	Compresor		x	x
9	6029020002	Condensador CF4G		x	x
9	6029020008	Condensador CF3G	x		
10	6021050004	Ventilador unidad condensadora 5w pata y pala	x		
10	6021050002	Ventilador unidad condensadora 10w		x	x
53	6021010025	Rele arranque compresor		x	x
54	6047010004	Filtro deshidratador	x		
54	6047010003	Filtro deshidratador		x	x
55	M107020001	Capilar		x	x
55	A107020004	Capilar	x		
109	6003010068	Pisacables 90°	x	x	x

Marca	Código	Denominación	CPH-3G-GI	CPH-4G-GI	CPH-5G-GI
1	6021350015	Termostato termo. refriger. ID 961F	x	x	x
2	6021130001	Interruptor bipolar luminoso ambar	x	x	x
3	6021130003	Piloto ambar indicador función	x	x	x
4	6021390006	Manguera 3x1x2500 mm. Blanca clavija schuko	x	x	x
6	C377010002	Cuadro de Mandos CCGN, CH-4, CFG, CPH	x	x	x
8	6021010004	Compresor	x		
8	6021010007	Compresor		x	x
9	6029020002	Condensador CF4G		x	x
9	6029020008	Condensador CF3G	x		
10	6021050004	Ventilador unidad condensadora 5w pata y pala	x		
10	6021050002	Ventilador unidad condensadora 10w		x	x
53	6021010025	Rele arranque compresor		x	x
54	6047010004	Filtro deshidratador	x		
54	6047010003	Filtro deshidratador		x	x
55	M107020001	Capilar		x	x
55	A107020004	Capilar	x		
109	6003010068	Pisacables 90°	x	x	x

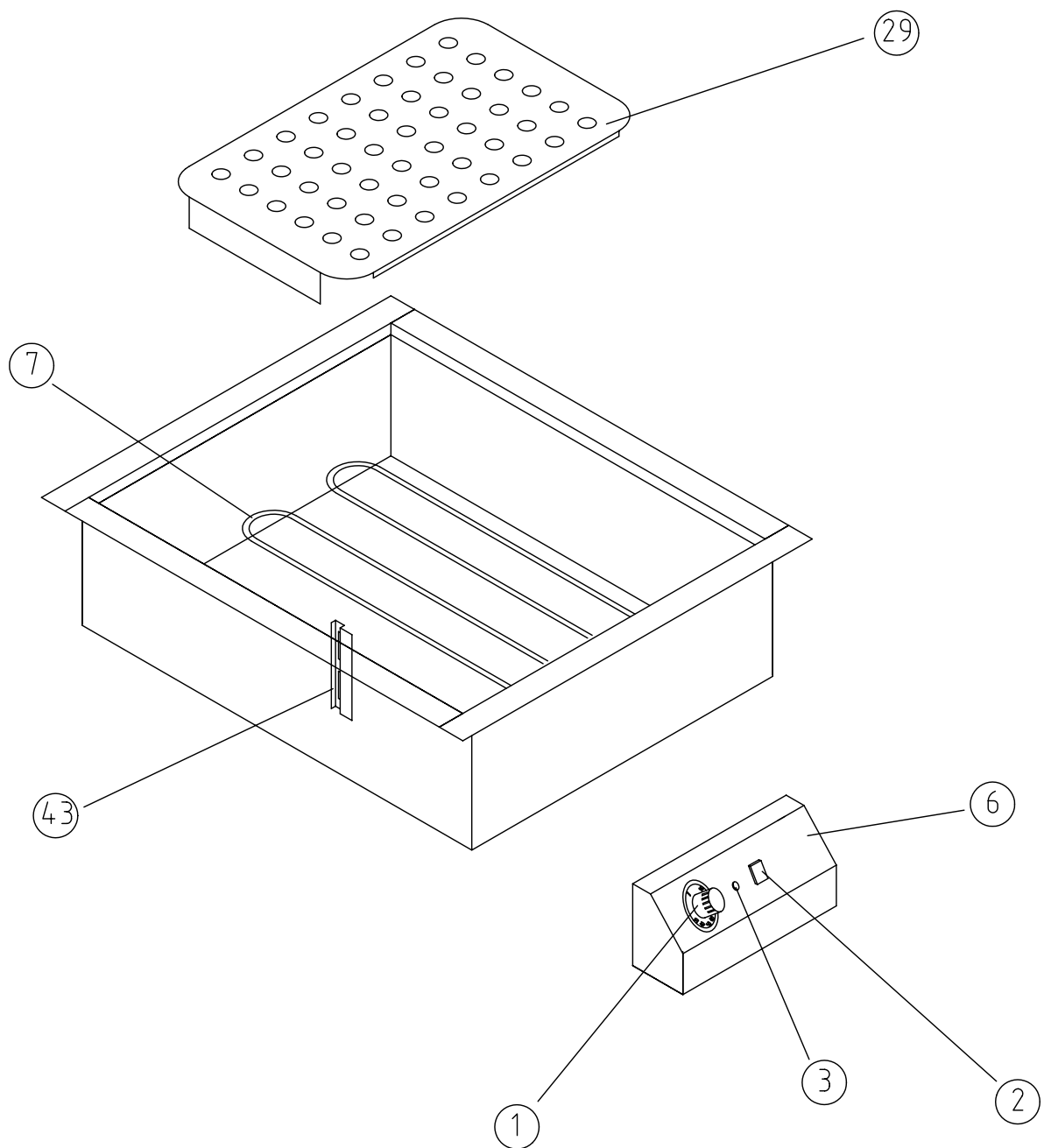

C3 CUBA CALIENTE CCGN COD. PIEZA: **X**

COTAS SIN TOLERANCIA DIN 7168-f

ANGULAR	GRADO TOLERANCIA	FINO	MEDIO	GRUESO
	HASTA 10 mm	±1°		±1° 30'
	MAS DE 10 A 50 mm	±30'		±50'
	MAS DE 50 A 120 mm	±20'		±25'
	MAS DE 120 A 400 mm	±10'		±15'
MAS DE 400 mm	±5'		±10'	

Material:

SUSTITUYE A:

Acabado:

SUSTITUIDO POR:

LINEAL	GRADO TOLERANCIA	FINO	MEDIO	GRUESO
	HASTA 3 mm	±0,05	±0,10	±0,15
	MAS DE 3 A 6 mm	±0,05	±0,10	±0,20
	MAS DE 6 A 30 mm	±0,10	±0,20	±0,50
	MAS DE 30 A 120 mm	±0,15	±0,30	±0,80
MAS DE 120 A 400 mm	±0,20	±0,50	±1,20	
MAS DE 400 A 1000 mm	±0,30	±0,80	±2,00	
MAS DE 1000 A 2000 mm	±0,50	±1,20	±3,00	

COMUN A	MODELO	Ud.	MODELO	Ud.	MODELO	Ud.	MODELO	Ud.	MODELO	Ud.
	CCGN		1							

A4	Nombre	Fecha
Dibujado	JAPM	.18-5-01
Comprobado		

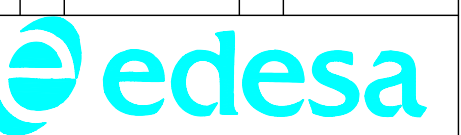

Escala	1:10
--------	------

RECAMBIOS CUBA CALIENTE

Código máquina:
CODIGO

Marca	Código	Denominación	CCGN-2	CCGN-3	CCGN-4	CCGN-5
1	6021350005	Termostato 0-90°C NT129BQ	x	x	x	x
2	6021130001	Interruptor bipolar luminoso ambar	x	x	x	x
3	6021130003	Piloto ambar indicador función	x	x	x	x
4	6021390006	Manguera 3x1x2500 mm. Blanca clavija schuko	x	x	x	x
6	C377010002	Cuadro de Mandos CCGN, CH-4, CFG, CPH	x	x	x	x
7	6021250028	Resistencia blindada "trabajo al aire" 800w	x			x
7	6021250029	Resistencia blindada "trabajo al aire" 1200w		x		x
7	6021250030	Resistencia blindada "trabajo al aire" 1600w			x	
29	C309050041	Fondo perforado CCGN	x	x	x	x
43	M409050002	Protector de sonda	x	x	x	x
109	6003010068	Pisacables 90°	x	x	x	x

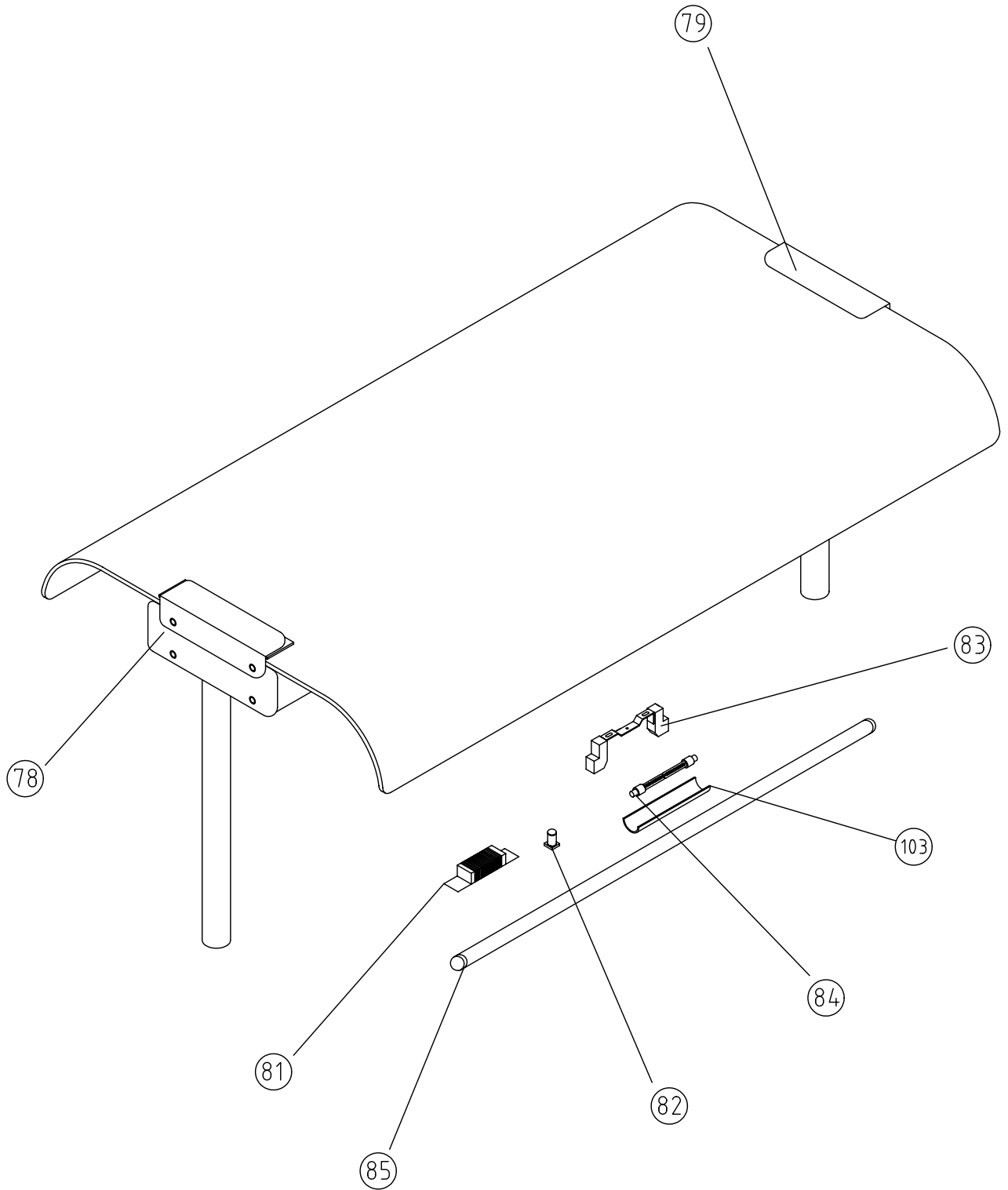

PANTALLA BUFFET N° X

1	PLANO RECAMBIOS	1	MATERIAL ESPESOR	.	.
---	-----------------	---	-------------------------	---	---

N°	Pieza	Uds.	Material	Acabado	N° Clasificación
----	-------	------	----------	---------	------------------

COMÚN A	MODELO	Ud.	MODELO	Ud.	MODELO	Ud.	MODELO	Ud.	MODELO	Ud.	MODELO	Ud.	COMÚN A
	PBLC	1											

	Firma	Fecha
Dibujado	JAPM	24-2-03
Proyectado		
Comprobado		



TOLERANCIAS GENERALES					
Lineal (mm)			Angular (°)		
±1	±2	±3	±1	±2	±3
Revisar cotas críticas cada 10 uds.					

Escala
1:10

PLANO RECAMBIOS

Código
CÓDIGO

Marca	Código	Denominación	PBLC-211	PBLC-311	PBLC-411	PBLC-511	PBL-211	PBL-311	PBL-411	PBL-511
78	P150010001	Tapa lateral pantalla	x	x	x	x	x	x	x	x
79	P150010002	Soporte Cristal a pantalla	x	x	x	x	x	x	x	x
81	6021290013	Reactancia 220/20w					x	x		
81	6021290014	Reactancia 220/40w							x	
81	6021290011	Reactancia 220/65w								x
82	6021290009	Cebador 4-22w 220 Ref. 258					x	x	x	
82	6021290010	Cebador 4-65w Ref. 1257								x
83	6021290015	Porta halogenos	x	x	x	x				
84	6021290016	Halogeno	x	x	x	x				
85	6021290002	Tubo fluorescente de 18w	x							
85	6021290004	Tubo fluorescente de 23w		x						
85	6021290003	Tubo fluorescente de 36w			x					
85	6021290005	Tubo fluorescente de 58w				x				
103	6035010032	Vidrio protección halogeno	x	x	x	x				

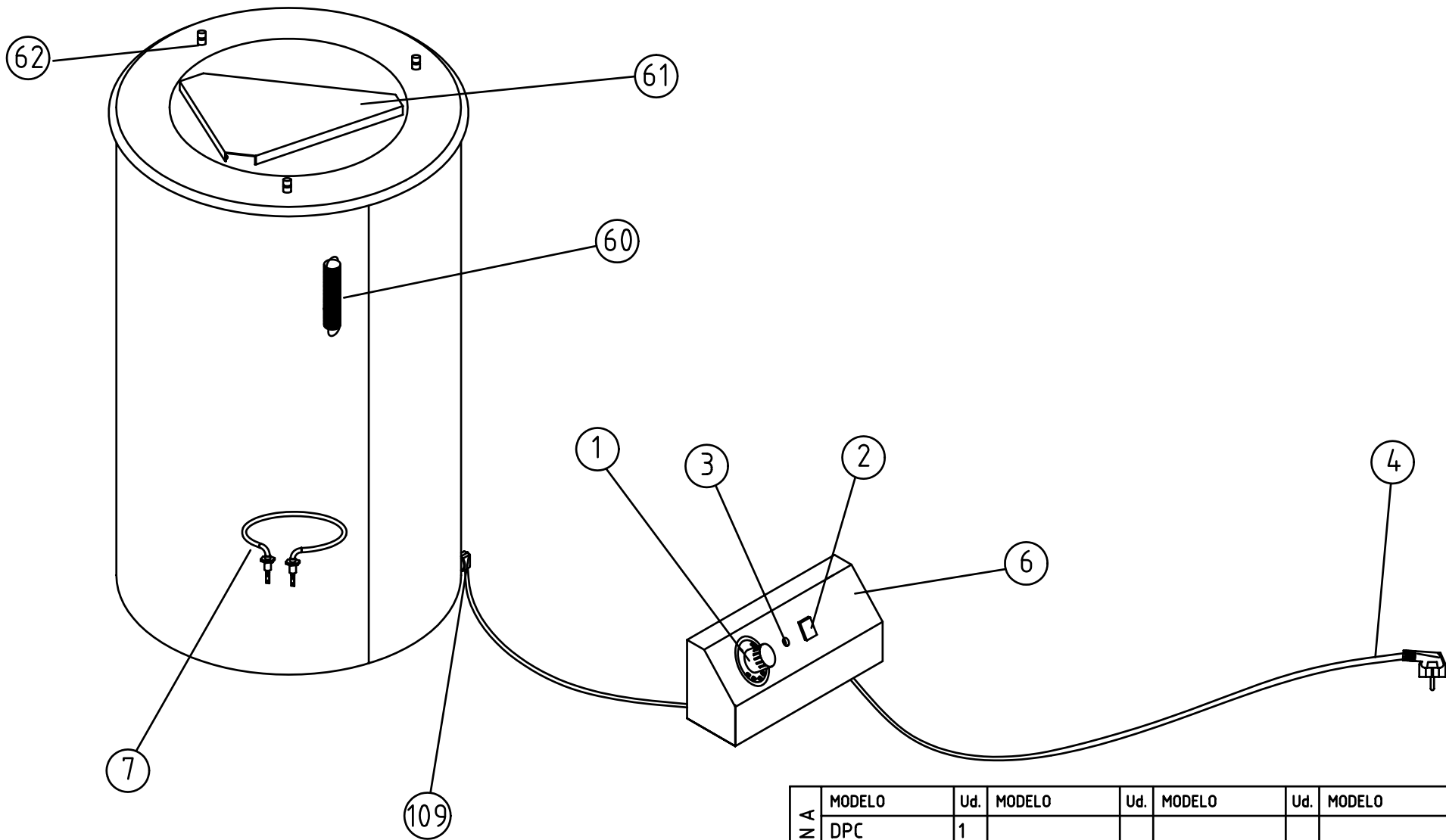

COMÚN A	MODELO	Ud.	MODELO	Ud.	MODELO	Ud.	MODELO	Ud.	MODELO
	DPC	1							
A4	Nombre		Fecha						
Dibujado	JAPM		6-3-03						
Comprobado	.		.						
Escala	RECAMBIOS DPC							Código máquina:	
1:9								CODIGO	

Marca	Código	Denominación	DPC-28	DPC-34
1	6021350005	Termostato 0-90°C NT129BQ	x	x
2	6021130001	Interruptor bipolar luminoso ambar	x	x
3	6021130003	Piloto ambar indicador función	x	x
4	6021390006	Manguera 3x1x2500 mm. Blanca clavija schuko	x	x
6	C377010002	Cuadro de Mandos CCGN, CH-4, CFG, CPH	x	x
7	6021250031	Resistencia 480w	x	x
25	6003010123	Rodamientos DPN sin eje	x	x
50	6025090038	Esparrago (sin apoyo cromado)	x	x
60	6033090015	Muelle tracción L-120 N° 3	x	x
61	D109010048	Base platos 28	x	
61	D109010049	Base platos 34		x
62	V107050001	Apoyo cromado sin tornillo	x	x
109	6003010068	Pisacables 90°	x	x

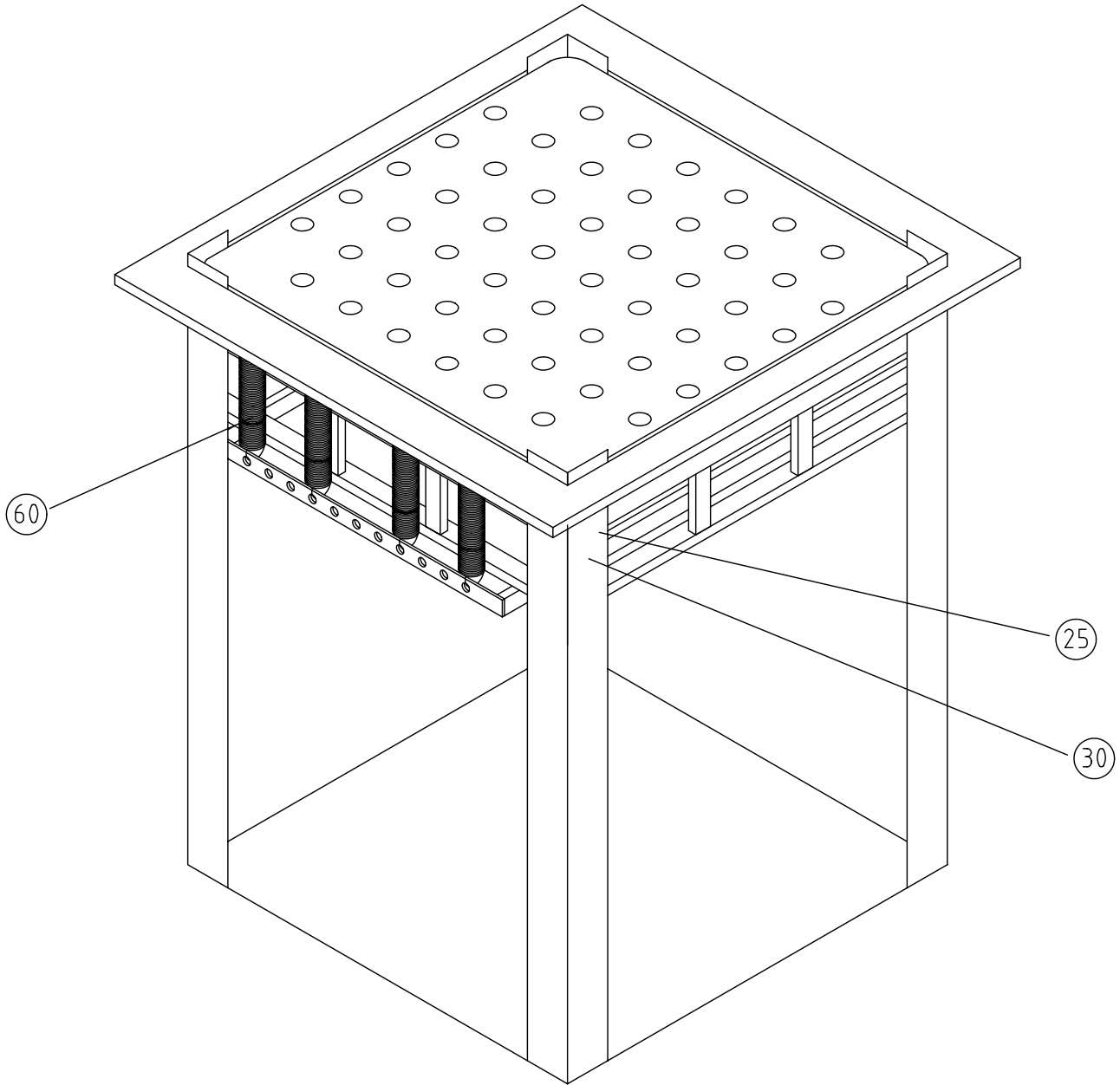

D1 DISPENSADOR NEUTRO PARA CESTAS DE VAJILLA COD. PIEZA: **X**

COTAS SIN TOLERANCIA DIN 7168-f Material: **INOX.** SUSTITUYE A:

Acabado: SUSTITUIDO POR:

ANGULAR	GRADO TOLERANCIA	FINO	MEDIO	GRUESO	COMUN A	MODELO	Ud.	MODELO	Ud.	MODELO	Ud.	MODELO	Ud.	MODELO	
	HASTA 10 mm		±1°			±1° 30'	DCN-50	1							
	MAS DE 10 A 50 mm		±30'			±50'									
	MAS DE 50 A 120 mm		±20'			±25'									
	MAS DE 120 A 400 mm		±10'			±15'									
MAS DE 400 mm		±5'		±10'											

LINEAL	GRADO TOLERANCIA	FINO	MEDIO	GRUESO	A 4	Nombre	Fecha	
	HASTA 3 mm	±0,05	±0,10	±0,15				
	MAS DE 3 A 6 mm	±0,05	±0,10	±0,20	Dibujado	JAPM	.31-1-01	
	MAS DE 6 A 30 mm	±0,10	±0,20	±0,50	Comprobado			
	MAS DE 30 A 120 mm	±0,15	±0,30	±0,80	Escala			
	MAS DE 120 A 400 mm	±0,20	±0,50	±1,20	1:8	RECAMBIOS DISPENSADOR DE CESTAS DE VAJILLA		
MAS DE 400 A 1000 mm	±0,30	±0,80	±2,00				CODIGO	
MAS DE 1000 A 2000 mm	±0,50	±1,20	±3,00					

Marca	Código	Denominación	DCN-55
25	6033090029	Rodamiento 608-ZR..	x
30	6025090026	Tornillo M8x20 zincado hexagonal DIN-933	x
60	6033090016	Muelle tracción L-150x25 ext. 2h inox. N° 1	x