

A1 ARMARIOS SERIE GN 2/1 (1 CUERPO)

COD. PIEZA: X

COTAS SIN TOLERANCIA DIN 7168-f

Material: MATERIAL ESPESOR

SUSTITUYE A:

Acabado: ACABADO

SUSTITUIDO POR:

ANGULAR	GRADO TOLERANCIA	FINO	MEDIO	GRUESO
	HASTA 10 mm	±1°		±1° 30'
	MAS DE 10 A 50 mm	±30'		±50'
	MAS DE 50 A 120 mm	±20'		±25'
	MAS DE 120 A 400 mm	±10'		±15'
MAS DE 400 mm	±5'		±10'	

COMÚN A	MODELO	Ud.	MODELO	Ud.	MODELO	Ud.	MODELO	Ud.
	APG-711	1						

LINEAL	GRADO TOLERANCIA	FINO	MEDIO	GRUESO
	HASTA 3 mm	±0,05	±0,10	±0,15
	MAS DE 3 A 6 mm	±0,05	±0,10	±0,20
	MAS DE 6 A 30 mm	±0,10	±0,20	±0,50
	MAS DE 30 A 120 mm	±0,15	±0,30	±0,80
	MAS DE 120 A 400 mm	±0,20	±0,50	±1,20
	MAS DE 400 A 1000 mm	±0,30	±0,80	±2,00
MAS DE 1000 A 2000 mm	±0,50	±1,20	±3,00	

A4	Nombre	Fecha
Dibujado	G.CH	.9-2-05
Modificado		
Escala	1:30	



RECAMBIOS APG-711

Código máquina:  
CODIGO

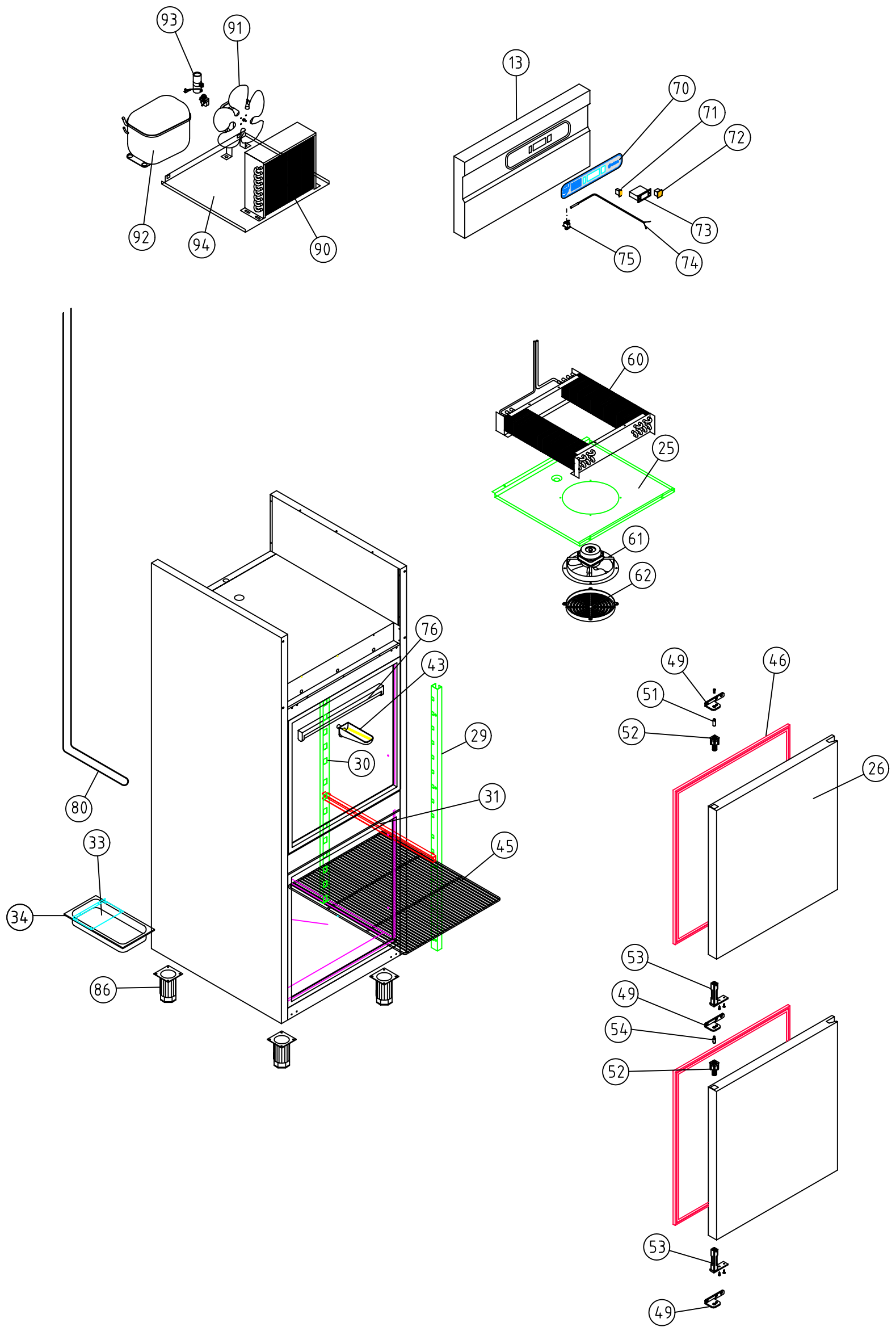

A1 ARMARIOS SERIE GN 2/1 (1 CUERPO)

COD. PIEZA: X

COTAS SIN TOLERANCIA DIN 7168-f

Material: MATERIAL ESPESOR

SUSTITUYE A:

Acabado: ACABADO

SUSTITUIDO POR:

ANGULAR	GRADO TOLERANCIA	FINO	MEDIO	GRUESO
	HASTA 10 mm	±1°		±1° 30'
	MAS DE 10 A 50 mm	±30'		±50'
	MAS DE 50 A 120 mm	±20'		±25'
	MAS DE 120 A 400 mm	±10'		±15'
MAS DE 400 mm	±5'		±10'	

COMÚN A	MODELO	Ud.	MODELO	Ud.	MODELO	Ud.	MODELO	Ud.
	APG-712	1						

LINEAL	GRADO TOLERANCIA	FINO	MEDIO	GRUESO
	HASTA 3 mm	±0,05	±0,10	±0,15
	MAS DE 3 A 6 mm	±0,05	±0,10	±0,20
	MAS DE 6 A 30 mm	±0,10	±0,20	±0,50
	MAS DE 30 A 120 mm	±0,15	±0,30	±0,80
	MAS DE 120 A 400 mm	±0,20	±0,50	±1,20
	MAS DE 400 A 1000 mm	±0,30	±0,80	±2,00
MAS DE 1000 A 2000 mm	±0,50	±1,20	±3,00	

A4	Nombre	Fecha
Dibujado	G.CH	.9-2-05
Modificado		
Escala	1:30	



RECAMBIOS APG-712

Código máquina:  
CODIGO

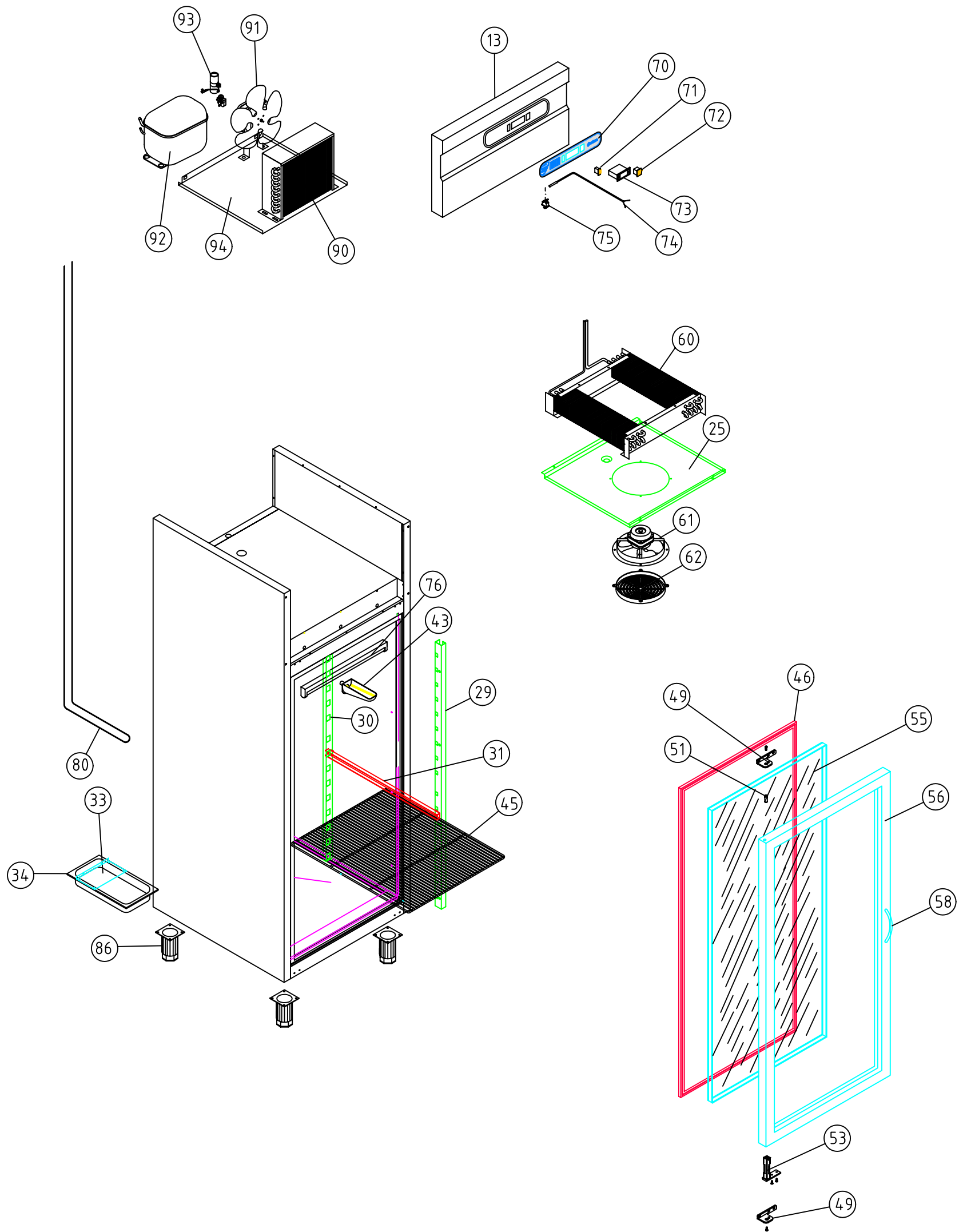

A1 ARMARIOS SERIE GN 2/1 (1 CUERPO)

COD. PIEZA: X

COTAS SIN TOLERANCIA DIN 7168-f

Material: MATERIAL ESPESOR

SUSTITUYE A:

Acabado: ACABADO

SUSTITUIDO POR:

ANGULAR	GRADO TOLERANCIA	FINO	MEDIO	GRUESO
	HASTA 10 mm	±1°		±1° 30'
	MAS DE 10 A 50 mm	±30'		±50'
	MAS DE 50 A 120 mm	±20'		±25'
	MAS DE 120 A 400 mm	±10'		±15'
MAS DE 400 mm	±5'		±10'	

COMÚN A	MODELO	Ud.	MODELO	Ud.	MODELO	Ud.	MODELO	Ud.
	APG-711-C	1						

LINEAL	GRADO TOLERANCIA	FINO	MEDIO	GRUESO
	HASTA 3 mm	±0,05	±0,10	±0,15
	MAS DE 3 A 6 mm	±0,05	±0,10	±0,20
	MAS DE 6 A 30 mm	±0,10	±0,20	±0,50
	MAS DE 30 A 120 mm	±0,15	±0,30	±0,80
	MAS DE 120 A 400 mm	±0,20	±0,50	±1,20
	MAS DE 400 A 1000 mm	±0,30	±0,80	±2,00
MAS DE 1000 A 2000 mm	±0,50	±1,20	±3,00	

A4	Nombre	Fecha
Dibujado	G.CH	.9-2-05
Modificado		
Escala	1:30	

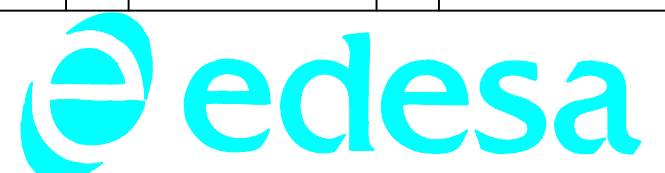

RECAMBIOS APG-711-C

Código máquina:  
CODIGO

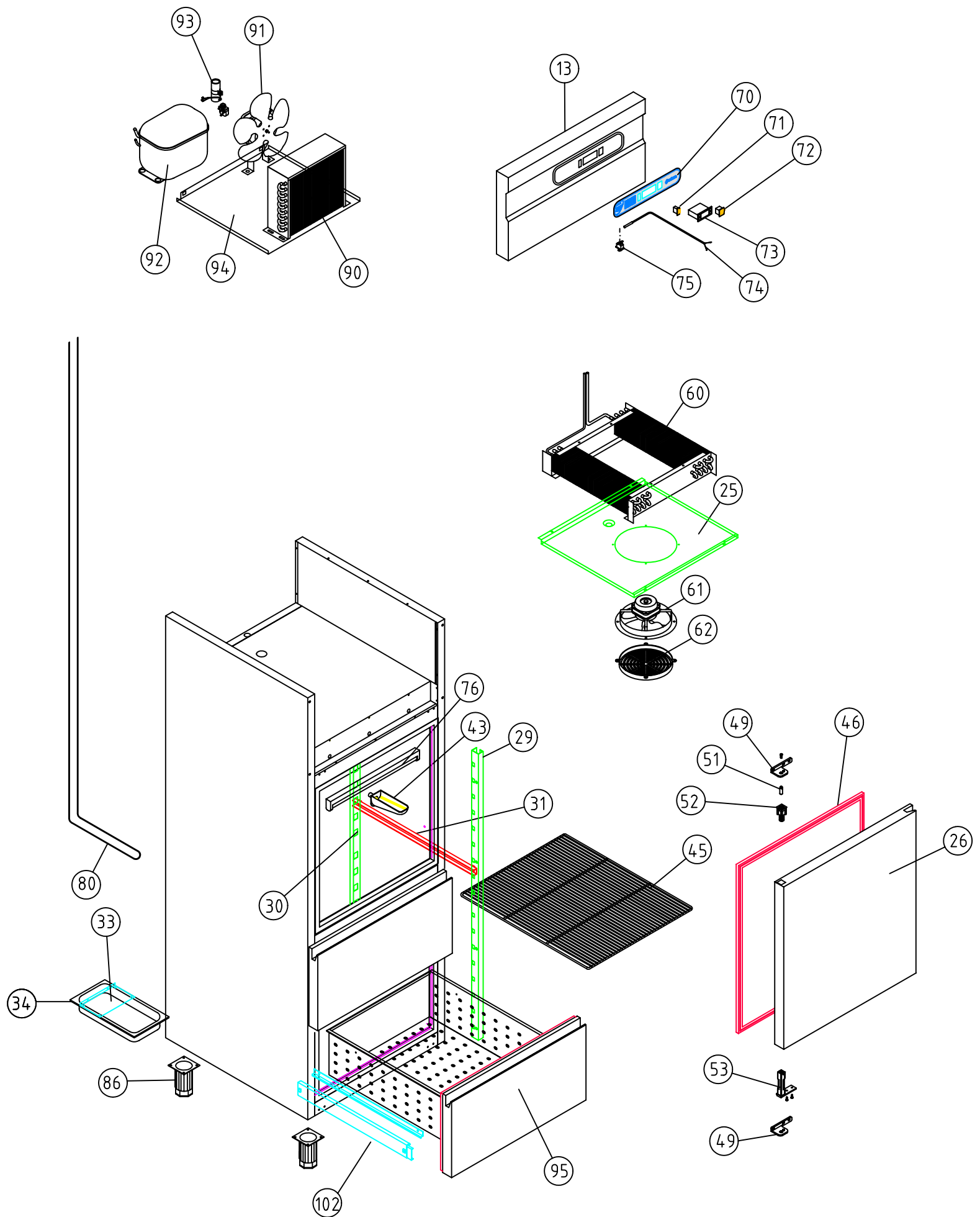

A1 ARMARIOS SERIE GN 2/1 (1 CUERPO)

COD. PIEZA: X

COTAS SIN TOLERANCIA DIN 7168-f

Material: MATERIAL ESPESOR

SUSTITUYE A:

Acabado: ACABADO

SUSTITUIDO POR:

ANGULAR	GRADO TOLERANCIA	FINO	MEDIO	GRUESO
	HASTA 10 mm	±1°		±1° 30'
	MAS DE 10 A 50 mm	±30'		±50'
	MAS DE 50 A 120 mm	±20'		±25'
	MAS DE 120 A 400 mm	±10'		±15'
MAS DE 400 mm	±5'		±10'	

COMÚN A	MODELO	Ud.	MODELO	Ud.	MODELO	Ud.	MODELO	Ud.
	APG-711-2C	1						

LINEAL	GRADO TOLERANCIA	FINO	MEDIO	GRUESO
	HASTA 3 mm	±0,05	±0,10	±0,15
	MAS DE 3 A 6 mm	±0,05	±0,10	±0,20
	MAS DE 6 A 30 mm	±0,10	±0,20	±0,50
	MAS DE 30 A 120 mm	±0,15	±0,30	±0,80
	MAS DE 120 A 400 mm	±0,20	±0,50	±1,20
	MAS DE 400 A 1000 mm	±0,30	±0,80	±2,00
MAS DE 1000 A 2000 mm	±0,50	±1,20	±3,00	

A4	Nombre	Fecha
Dibujado	G.CH	.9-2-05
Modificado		
Escala	1:30	



RECAMBIOS APG-711-2C

Código máquina:  
CODIGO

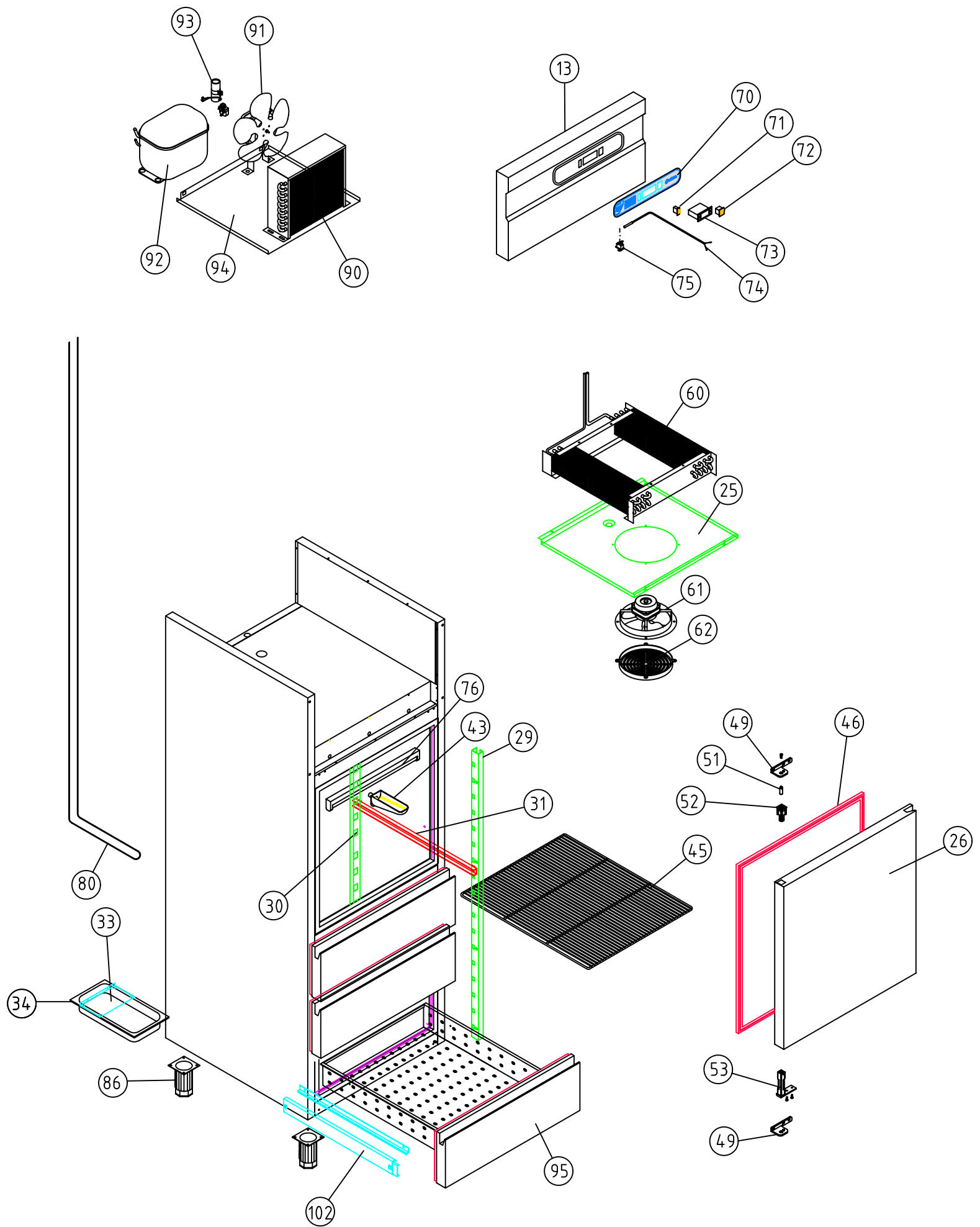

A1 ARMARIOS SERIE GN 2/1 (1 CUERPO)

COD. PIEZA: X

COTAS SIN TOLERANCIA DIN 7168-f

Material: MATERIAL ESPESOR

SUSTITUYE A:

Acabado: ACABADO

SUSTITUIDO POR:

ANGULAR	GRADO TOLERANCIA	FINO	MEDIO	GRUESO
	HASTA 10 mm	±1°		±1° 30'
	MAS DE 10 A 50 mm	±30'		±50'
	MAS DE 50 A 120 mm	±20'		±25'
	MAS DE 120 A 400 mm	±10'		±15'
MAS DE 400 mm	±5'		±10'	

COMÚN A	MODELO	Ud.	MODELO	Ud.	MODELO	Ud.	MODELO	Ud.
	APG-711-3C	1						

LINEAL	GRADO TOLERANCIA	FINO	MEDIO	GRUESO
	HASTA 3 mm	±0,05	±0,10	±0,15
	MAS DE 3 A 6 mm	±0,05	±0,10	±0,20
	MAS DE 6 A 30 mm	±0,10	±0,20	±0,50
	MAS DE 30 A 120 mm	±0,15	±0,30	±0,80
	MAS DE 120 A 400 mm	±0,20	±0,50	±1,20
	MAS DE 400 A 1000 mm	±0,30	±0,80	±2,00
MAS DE 1000 A 2000 mm	±0,50	±1,20	±3,00	

A4	Nombre	Fecha
Dibujado	G.CH	.9-2-05
Modificado		
Escala	1:30	

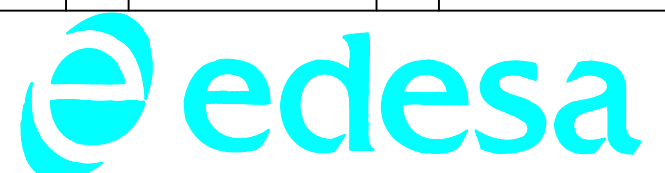

RECAMBIOS APG-711-3C

Código máquina:  
CODIGO

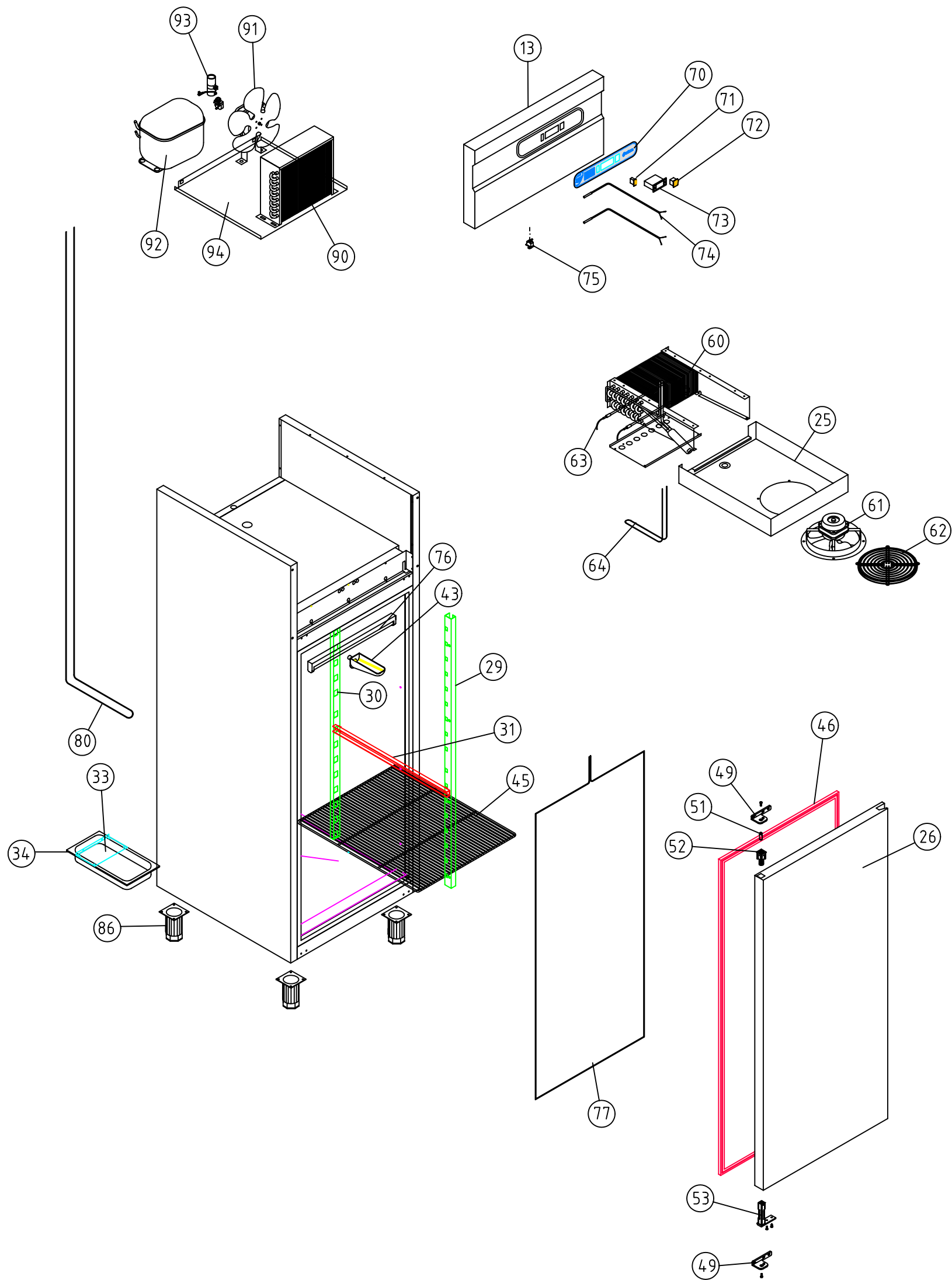

A1 ARMARIOS SERIE GN 2/1 MANT. CONGEL.(1 CUERPO)

COD. PIEZA: X

COTAS SIN TOLERANCIA DIN 7168-f

Material: MATERIAL ESPESOR

SUSTITUYE A:

Acabado: ACABADO

SUSTITUIDO POR:

ANGULAR	GRADO TOLERANCIA	FINO	MEDIO	GRUESO
	HASTA 10 mm	±1°		±1° 30'
	MAS DE 10 A 50 mm	±30'		±50'
	MAS DE 50 A 120 mm	±20'		±25'
	MAS DE 120 A 400 mm	±10'		±15'
MAS DE 400 mm	±5'		±10'	

COMÚN A	MODELO	Ud.	MODELO	Ud.	MODELO	Ud.	MODELO	Ud.
	ANG-711	1						

LINEAL	GRADO TOLERANCIA	FINO	MEDIO	GRUESO
	HASTA 3 mm	±0,05	±0,10	±0,15
	MAS DE 3 A 6 mm	±0,05	±0,10	±0,20
	MAS DE 6 A 30 mm	±0,10	±0,20	±0,50
	MAS DE 30 A 120 mm	±0,15	±0,30	±0,80
	MAS DE 120 A 400 mm	±0,20	±0,50	±1,20
	MAS DE 400 A 1000 mm	±0,30	±0,80	±2,00
MAS DE 1000 A 2000 mm	±0,50	±1,20	±3,00	

A4	Nombre	Fecha
Dibujado	G.CH	.9-2-05
Modificado		
Escala	1:30	

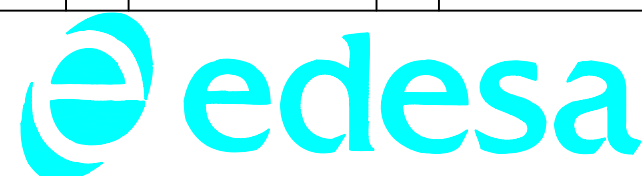

RECAMBIOS ANG-711

Código máquina:  
CODIGO

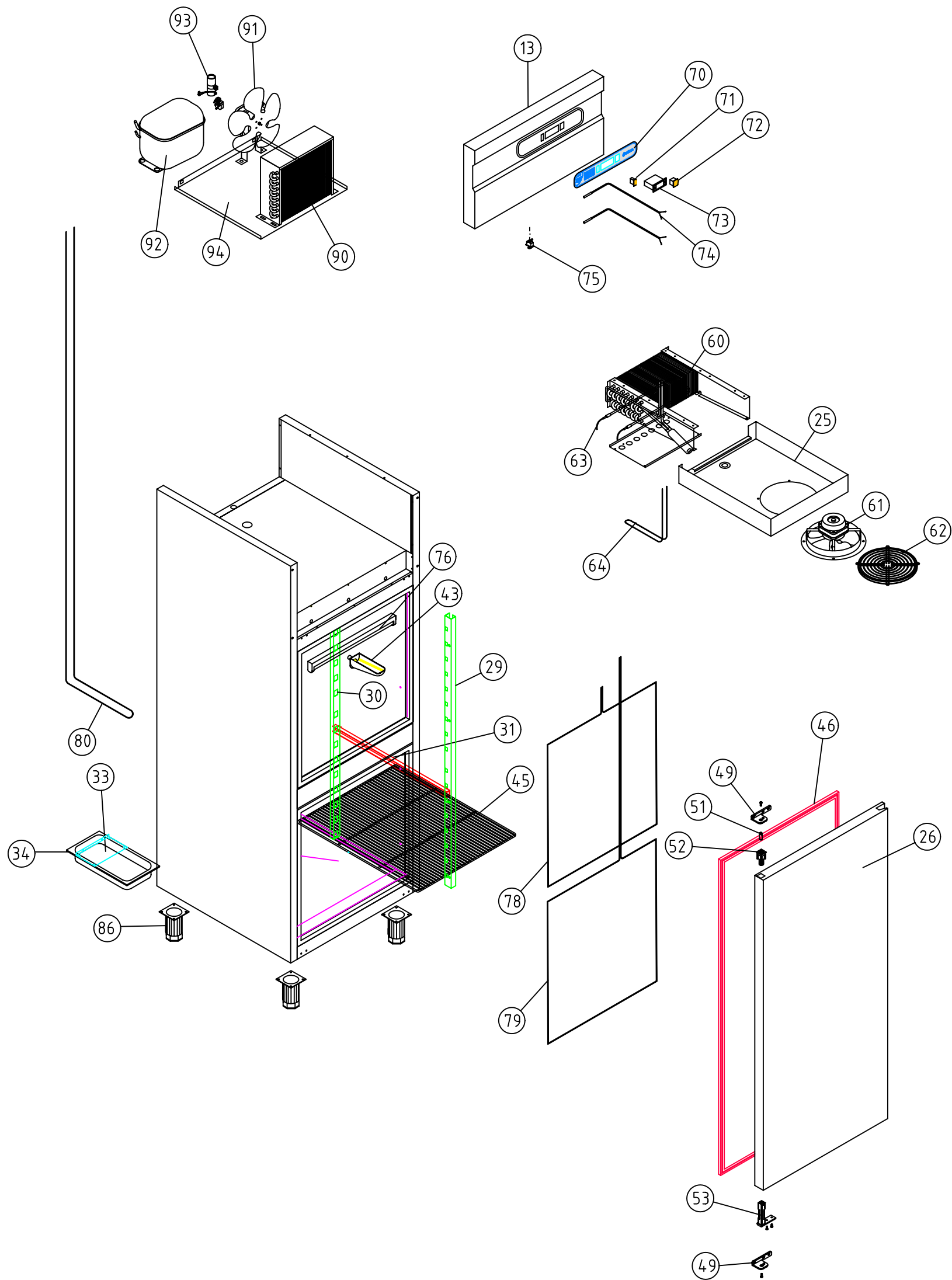

A1 ARMARIOS SERIE GN 2/1 MANT. CONGEL.(1 CUERPO)

COD. PIEZA: X

COTAS SIN TOLERANCIA DIN 7168-f

Material: MATERIAL ESPESOR

SUSTITUYE A:

Acabado: ACABADO

SUSTITUIDO POR:

ANGULAR	GRADO TOLERANCIA	FINO	MEDIO	GRUESO
	HASTA 10 mm	±1°		±1° 30'
	MAS DE 10 A 50 mm	±30'		±50'
	MAS DE 50 A 120 mm	±20'		±25'
	MAS DE 120 A 400 mm	±10'		±15'
MAS DE 400 mm	±5'		±10'	

COMÚN A	MODELO	Ud.	MODELO	Ud.	MODELO	Ud.	MODELO	Ud.
	ANG-712	1						

LINEAL	GRADO TOLERANCIA	FINO	MEDIO	GRUESO
	HASTA 3 mm	±0,05	±0,10	±0,15
	MAS DE 3 A 6 mm	±0,05	±0,10	±0,20
	MAS DE 6 A 30 mm	±0,10	±0,20	±0,50
	MAS DE 30 A 120 mm	±0,15	±0,30	±0,80
	MAS DE 120 A 400 mm	±0,20	±0,50	±1,20
	MAS DE 400 A 1000 mm	±0,30	±0,80	±2,00
MAS DE 1000 A 2000 mm	±0,50	±1,20	±3,00	

A4	Nombre	Fecha
Dibujado	G.CH	.9-2-05
Modificado		
Escala	1:30	

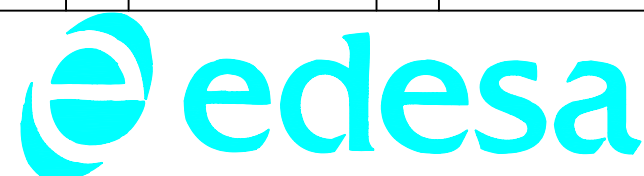

RECAMBIOS ANG-712

Código máquina:  
CODIGO

		RECAMBIOS ARMARIOS APG-ANG 700	APG-711	APG-712	APG-711-C	APG-711-2C	APG-711-3C	ANG-711	ANG-712
									
N°	códigos	DESCRIPCION							
13	A109010262	CABEZA CON EMBUTICION APG-700	1	1		1	1	1	1
13	A109010263	CABEZA CON EMBUTICION PUERTA CRISTAL APG-700			1				
25	A109010202	TAPA DEL EVAPORADOR APG-700	1	1	1	1	1		
25	A109050184	CAJA SUJEC. VENTIL. FC-71						1	1
26	A169010057/58	PUERTA PEQUEÑA APS 713x683		2		1	1		2
27	A169010059/60	PUERTA CARNICERA APS 1446x683	1					1	
29	A109050323	CREMALLERA DELANTERA APG	2		2			2	
29	A109050324	CREMALLERA DELANTERA CHICA APG		4		2	2		4
30	A109050325	CREMALLERA INTERIOR APG	2	2	2	2	2	2	2
31	6033050012	GUIA GN L=613	6	6	6	4	4	6	6
34	6041090003	CUBETA GN 1/3 prof. 40	1	1	1	1	1	1	1
43	6003010184	Desagüe Canalizador agua 150 gris	1	1	1	1	1		
43	6003010192	Desagüe Canalizador agua 150 negro						1	1
45	6027010009	Parrilla GN 2/1 650x530	3	3	3	3	3	3	3
46	6045010088	Burlete gris ref.153 de 675x705 puerta PEQUEÑA		2		1	1		2
46	6045010089	Burlete gris ref.153 de 675x1435 puerta CARNIC	1					1	
46	6045010075	Burlete gris ref.153 de 1425 x 662			1				
49	6033010083	Soporte bisagra DB-516 inf.izdo. FAJOTA	2	3		2	2	2	3
49	6033010088	Soporte bisagra PUERTA CRISTAL inf.izdo. PISSAL			2				
50	6033010089	Soporte bisagra PUERTA CRISTAL inf.dcho. PISSAL							
51	C207050005	Eje sup.puertas 30x10 varilla inox. roscado int.M-6	1	1	1	1	1	1	1
52	6003010136	Caja alojamiento muelle gris	1	2		1	1	1	2
53	6033010003	Bisagra TRS1D doble muelle cromada	1	2	1	1	1	1	2
54	6033900068	Eje intermedio puertas 30x10 varilla inox. rosc.exterior		1					1
55	6035130067	Termofload 1390 x 628 4/18/4			1				
56	A107130002	Marco perfil aluminio 1446 x 683 (Apariencia inox sati) IZDO.			1				
58	6033010002	Tirador asa cromada para MEP de (Navarro Azorin)			1				
60	A129010014	Bateria 8T 4R 330A 4S (2 BLOQUES)	1	1	1	1	1		
60	A129010006	FC-71-B Bat.7T 5R 300A 6S						1	1
61	6021050038	Ventilador del evaporador 10W pala 200 34°	1	1	1	1	1		
61	6021050054	ARO de 220 sin patillas	1	1	1	1	1		
61	6021050010	Ventil. aro 10w 230v Arm.diam.200 FC-62B angulo 34°						1	1
62	6027130010	Rejilla proteccion vent.D.220 pintada gris	1	1	1	1	1		
62	6027130001	Rejilla vent. D.246 pintada						1	1
63	6021250019	Resistencia blindada FC61-71 350w 1000						1	1
63	6021250022	Resistencia blindada FC62-72 650w 1000							
64	6021250011	Resistencia desagüe congelación 18w						1	1
70	6023010216	PEGATINA 345x68 CUADRO ARMARIO	1	1	1	1	1	1	1
71	6021130002	Interruptor unipolar lumin.ambar O/I	1	1	1	1	1	1	1
72	6021130001	Interruptor bipolar ambar O/I contactos reforz.	1	1	1	1	1	1	1
73	6021350052	Termostato AKO-14128 220v 50/60Hz Num. 04244739	1	1	1	1	1		
73	6021350061	AKO-14323 220v 50/60Hz Num.						1	1
74	6021350013	Sonda NTC 1.5 m	1	1	1	1	1	2	2
75	6021130008	Microrruptor rectang.Luce ref.10005172	1	1	1	1	1	1	1
76	6021290052	Iluminacion Fluorescente 8 w ref. 80015/8	1	1	1	1	1		
77	6021250009	Resistencia marco ext.700-800 43w						1	
78	6021250013	Resistencia marco puerta sup. 28w							1
79	6021250014	Resistencia marco puerta inf. 28w							1
80	6021250006	Resistencia evaporación automática 41w	1	1	1	1	1	1	1
86	6007050017	Pata regul.armario gastro	4	4	4	4	4	4	4
90	6029020002	condensador 9x2	1	1	1	1	1		
90	6029020005	condensador 10x4						1	1
91	6021050002	Ventilador 10 W pala 254 22° 230V 50Hz (con pie de 84)	1	1	1	1	1	1	1
92	6021010007	Compresor Danfoss FR-8.5-G 220V 50Hz	1	1	1	1	1		
92	6021010002	Compresor Danfoss SC-15-CL						1	1
93	6021010037	CONDEN. ARRANQUE FR-8.5-G 117U5015 DANFOSS	1	1	1	1	1		
93	6021010035	CONDEN. ARRANQUE SC 117U5017 80MF						1	1
94	A109170015	BANCADA AP,APP,AFP,AFN,VC,CF	1	1	1	1	1	1	1
95	A169120001	CAJON 1/2 APG-711-2C				2			
95	A169120002	CAJON 1/3 APG-711-3C					3		
100	6045010080	Burlete gris ref.153 de 675x378 puerta CAJON				2			
100	6045010079	Burlete gris ref.153 de 675x218 puerta CAJON					3		
102	6033050006	GUIA ACERO L550 COMPLEX ( juegos)				2	3		